

# D1000

Regenerative Converter Unit



# THE POWER REGENERATIVE CONVERTER UNIT

The D1000 regenerative converter unit complements the Yaskawa product range with a low harmonics Active Front End solution. Suitable for both regenerative individual drives and systems of inverter drives, servo axis or robots, the D1000 feeds excess braking energy back into the power grid instead of dissipating it as heat.



## Energy efficient

D1000 saves energy by redirecting braking energy back onto the grid, to be used by other devices, instead of wasting it as heat. By providing full braking power with 100% duty cycle capabilities, the D1000 allows for shorter machine cycles and can increase production efficiency.

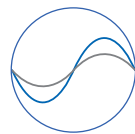

## Clean power

The sinusoidal input current with a total harmonic current distortion of less than 5% and a displacement power factor of ~1 minimize losses in grid components like generators and transformers.



## Cool operation

D1000 does away with braking choppers and resistors, thus saving valuable space and reducing the risk of fire by eliminating open heating elements. By not dissipating energy as heat the demand for ventilation is greatly reduced and maintenance (resistor cleaning) is eliminated.



## Reduce costs

The D1000's energy saving capability lowers utility bills, while also expanding the existing power supply capability through heat reductions made possible by its lower input harmonic performance and regenerative capabilities.



## Ready for global use

D1000 complies with major global standards such as UL, CE, RoHS and others.

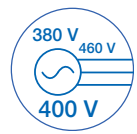

## Regulated DC bus

A controlled, boostable DC voltage guarantees the same level of DC voltage independent of the power supply voltage. Connected drives are always supplied with the same DC voltage, making machines invulnerable against locally different power supply conditions and assuring the same machine performance, no matter where it is used.



## Easy to handle package

D1000 comes in an easy to handle kit. Only one part number for all components makes procurement simple and assures completeness and parts compatibility.



# Save Energy with Power Regeneration

D1000 is open for various configurations. Usable in one-on-one or multiple unit connection the D1000 provides the flexibility needed to satisfy a broad range of energy efficient and low harmonics applications.

# For a Wide Range of Applications

Using the D1000 regenerative converter unit saves energy and thereby money within a broad range of applications. This includes applications with large-inertia loads, 4-quadrant loads, long-term energy feedback and quick braking.

## 1:n Configuration

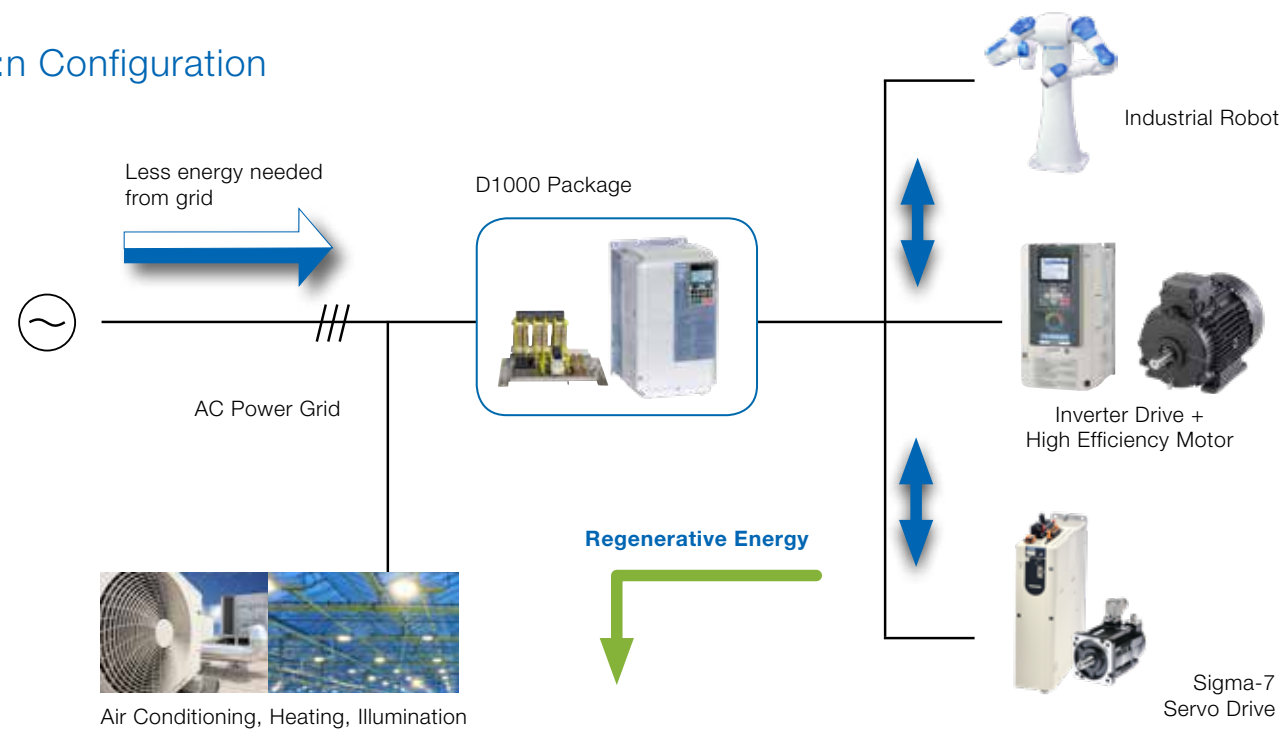

## One-on-one system

Typical one-on-one applications like escalators, elevators, or presses have one inverter drive connected to a D1000.

Using the D1000 they take great benefit from:

- Energy cost reduction of complete installation
- Less space and heat by removed braking resistors
- Low input current harmonics facilitating IEEE 519 compliance

## Multiple-unit connection

Multiple unit systems like winders, transport systems, or packaging systems with inverter drives, servo systems or robots have an interconnected DC bus that is supplied by a single D1000. Energy is already shared in the DC bus, leading to reduced power draw from the power grid.

In addition to the benefit of one-on-one systems such applications take advantages from:

- DC bus energy sharing
- Reduced space compared to multiple drives with built-in active frontend
- Single point of supply



Motor Test Benches



Robots



Dynamometers



Winders



Elevators



Escalators



Centrifugal Separators



Presses

# Package Selection

# Calculating the Capacity for Multiple Units

## Single Unit Configuration (1:1)

For configurations with only one drive connected to a D1000 the correct D1000 Kit can be selected from the tables below.

### 200 V Class

Recommended Total Motor Load HP (kW)	D1000 System Kit Number
5 (3.7)	D1000-240-5HP
10 (7.5)	D1000-240-10HP
20 (15)	D1000-240-20HP
30 (22)	D1000-240-30HP
50 (37)	D1000-240-50HP
75 (55)	D1000-240-75HP
100 (75)	D1000-240-100HP
150 (110)	D1000-240-150HP

### 400 V Class

Recommended Total Motor Load HP (kW)	D1000 System Kit Number
5 (3.7)	D1000-480-5HP
10 (7.5)	D1000-480-10HP
20 (15)	D1000-480-20HP
30 (22)	D1000-480-30HP
40 (30)	D1000-480-40HP
60 (45)	D1000-480-60HP
100 (75)	D1000-480-100HP
150 (110)	D1000-480-150HP
200 (160)	D1000-480-200HP
300 (220)	D1000-480-300HP
400 (315)	D1000-480-400HP
750 (560)	D1000-480-750HP

## Multiple Unit Configuration (1:n)

Selecting the optimal D1000 Kit when multiple units are connected to one D1000 requires an analysis of the application. Find the moments of maximum motoring and regenerative power as shown in the example below, compare them and select the right D1000 kit.

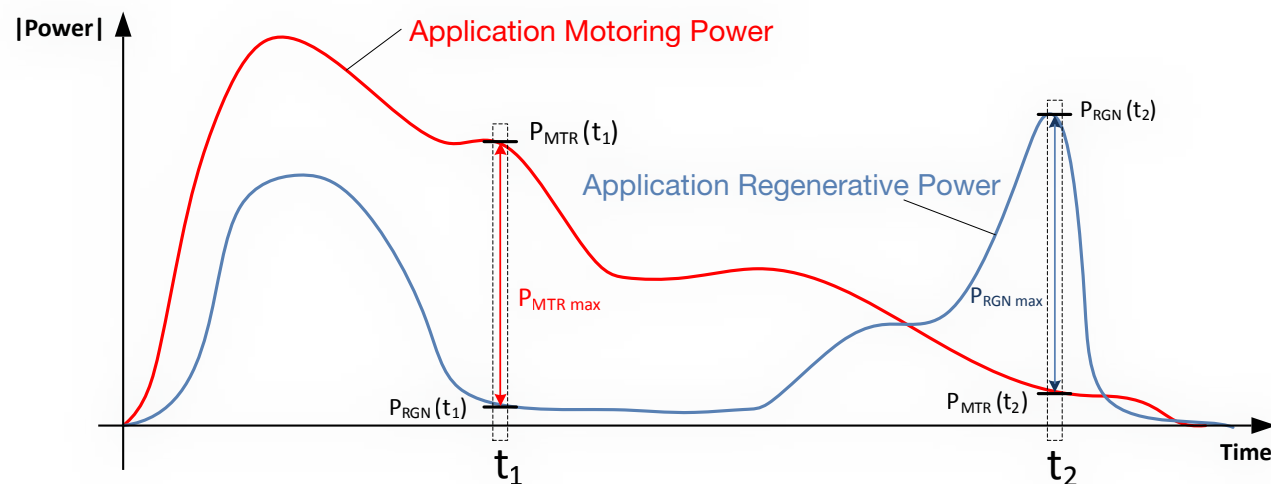

### Definitions

$P$  = Power [kW]

$\eta$  = Efficiency

$P_{MTR}$  = Motoring Power

$P_{RGN}$  = Regenerative Power

$$P_{MTR}(t) = \sum_{i=1}^N \frac{P_{Motor\ i}(t)}{\eta_{Motor\ i} \cdot \eta_{drive\ i}}$$

$$P_{RGN}(t) = \sum_{i=1}^N P_{Motor\ i}(t) \cdot \eta_{Motor\ i} \cdot \eta_{drive\ i}$$



1. Determine the moment ( $t_1$ ) when the application draws the maximum motoring power from the grid and calculate the power by subtracting the total motoring and regenerative values.

$$P_{MTR\ max} = P_{MTR}(t_1) - P_{RGN}(t_1)$$

2. Determine the moment ( $t_2$ ) when the application returns the maximum regenerative power to the grid, and calculate the power by subtracting the total regenerative and motoring values.

$$P_{RGN\ max} = P_{RGN}(t_2) - P_{MTR}(t_2)$$

3. Select a D1000 with a power rating greater than

$$P_{MTR\ max} \text{ or } P_{RGN\ max}, \text{ (whichever is higher).}$$

## Notes

- The minimum D1000 power rating is 1/3 of the total nominal power rating of all devices connected to the DC bus.
- If the peak power state has a duration of less than 60 seconds, the D1000 overload capability can be taken into account. This requires a closer analysis of the application. For technical assistance please contact Yaskawa support.
- If efficiencies are unknown, use a motor efficiency of 0.9 (0.85 for motors <7.5 kW) and a drive efficiency of 0.95.
- When calculating the motoring or regenerative power, the actual shaft power should be used. This is because some devices like SERVOPACKS can provide up to 300% of nominal power for a short time, which can have significant influence on D1000 selection.
- When connecting devices to the DC bus that do not have their own precharge circuit there is a limit to the amount of capacitance that can be connected to the D1000. For more information please contact Yaskawa support.
- If the interphase imbalance ratio of the power source exceeds 2%, select a D1000 unit one size larger than required by the above calculation.

## Model Designation

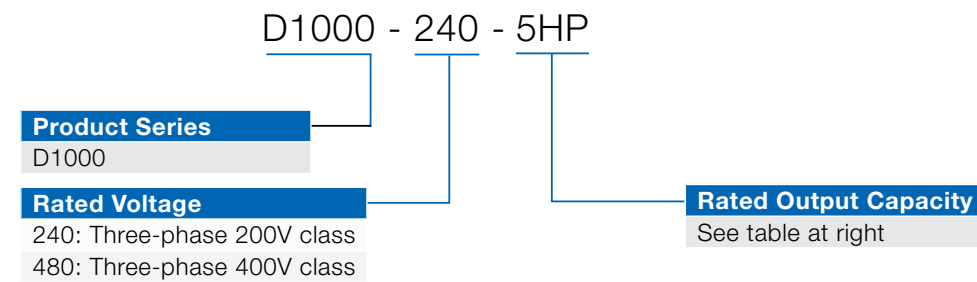

## Features

- Facilitates IEEE 519 Compliance
- Less than 5% iTHD at input terminals
- Supports single-drive or multi-drive common bus configurations
- Compatible with all conventional drives having full power access to DC bus
- Overload capability of 150% for 30 seconds, 200% for 3 seconds
- Near unity true power factor at full load
- Ability to compensate for low voltage (boost function)
- Overcurrent and overheat protection

## D1000 Package Kit Includes:

- D1000 Regenerative Converter Unit
- Input Reactor(s)
- Harmonic Filter Module or Harmonic Filter Kit

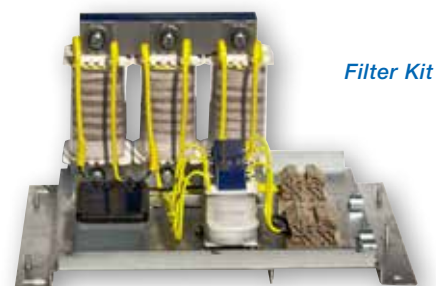

## Capacities and Dimensions

Each active rectifier system requires a D1000 power module, filter module, and reactor(s). These systems are sold together as a single kit number as follows:

	System Kit Number	System Capacity <sup>*1</sup>			
		Recommended Total Motor Load HP (kW)	Maximum Continuous		
			Output Power (HP)	Output DC Current (DC Amps)	Input AC Current (AC Amps)
240VAC Input (325V DC Output)	D1000-240-5HP	5 (3.7)	6.7	15	15
	D1000-240-10HP	10 (7.5)	13.4	30	29
	D1000-240-20HP	20 (15)	26.8	61	57
	D1000-240-30HP	30 (22)	40	91	83
	D1000-240-50HP	50 (37)	67	152	140
	D1000-240-75HP	75 (55)	87	197	200
	D1000-240-100HP	100 (75)	120	273	270
	D1000-240-150HP	150 (110)	174	394	400
480VAC Input (650V DC Output)	D1000-480-5HP	5 (3.7)	6.7	8	8
	D1000-480-10HP	10 (7.5)	13.4	15	16
	D1000-480-20HP	20 (15)	26.8	30	30
	D1000-480-30HP	30 (22)	40	45	43
	D1000-480-40HP	40 (30)	54	61	58
	D1000-480-60HP	60 (45)	80	91	86
	D1000-480-100HP	100 (75)	134	152	145
	D1000-480-150HP	150 (110)	174	197	210
	D1000-480-200HP	200 (160)	250	280	300
	D1000-480-300HP	300 (220)	360	409	410
	D1000-480-400HP	400 (315)	500	561	560
D1000-480-750HP	750 (560)	850	955	1040	

<sup>\*1</sup> Recommended load is stated to account for typical efficiencies of connected loads (e.g. drives and motors). Maximum continuous values can be used if specific load device efficiencies are considered.

<sup>\*2</sup> Dimensions shown only for D1000 power modules. Contact Yaskawa for dimensions of other components included in kit number.

# Specifications / Options

# Connection Diagram

## Specifications

Operating Environment																				
Ambient Temperature	-10 to +50 °C (IP00)																			
Humidity	95 % RH or less (non condensating)																			
Storage Temperature	-20 to +60 °C (short-term temperature during transportation)																			
Altitude	Up to 1000 m (output derating required above 1000 m, max. 3000 m)																			
Vibration/Shock	10 to 20 Hz at 9.8 m/s <sup>2</sup> , 20 to 55 Hz at 5.9 m/s <sup>2</sup> (2A0005 to 2A0050, 4A0005 to 4A0100)																			
	10 to 20 Hz at 9.8 m/s <sup>2</sup> , 20 to 55 Hz at 2.0 m/s <sup>2</sup> (2A0065 to 2A0130, 4A0130 to 4A0370)																			
	10 to 20 Hz at 5.9 m/s <sup>2</sup> , 20 to 55 Hz at 2.0 m/s <sup>2</sup> (4A0630)																			
Protection Design	IP00/IP20 Open Type enclosure, Indoor use																			
Standards	UL508C, IEC 61800-5-1, IEC 61800-3, RoHS																			
Power Ratings																				
Models	200 V Class (CIMR-DU2A□□□□)							400 V Class (CIMR-DU4A□□□□)												
	0005	0010	0020	0030	0050	0065	0090	0100	01010	01020	01030	01040	01060	01100	01130	01185	01270	01370	01630	
Maximum Applicable Motor Capacity (HP) <sup>*1</sup>	5	10	20	30	50	75	100	150	5	10	20	30	40	60	100	150	200	300	400	750
Rated Output Capacity (HP) <sup>*1</sup>	6.7	13.4	26.8	40	67	87	120	174	6.7	13.4	26.8	40	54	80	134	174	250	360	500	850
Rated Output Current DC (A)	15	30	61	91	152	197	273	394	8	15	30	45	61	91	152	197	280	409	561	955
Rated Input Current AC (A)	15	29	57	83	140	200	270	400	8	16	30	43	58	86	145	210	300	410	560	1040
Rated Output Voltage (VDC)	330							660												
Overload Capability	Operation stops after 60s at 150 % of rated output current																			
Rated Voltage	200 to 240 VAC -15 bis +10 %							380 to 480 VAC -15 bis +10 %												
Rated Frequency	50/60Hz ± 2 %																			
Input Power Factor	Input power factor of 0.99 min (for rated operation)																			
Output Voltage Accuracy	±5 %																			
Carrier Frequency (kHz)	6			4				6			4			2						

\*1: Rated output capacity is calculated with a rated input voltage of 220 V for 200 V Class and 440 V for 400 V Class

## Options

Input / Output		
Analog Monitor	2 channel analog output option (-10 to +10VDC (Res. 1/2048))	AO-A3
Digital Output	Optional: 8 channel digital output option (6 photo couplers (48V, 50 mA or less), 2 relay contact outputs max. 250VAC / 30VDC, 1 A)	DO-A3
Communication		
Communication Interface Units	CANopen	SI-S3
	CC-Link	SI-C3
	DeviceNet	SI-N3
	EtherCAT	SI-ES3
	EtherNet/IP (Single-Port, Dual Port)	SI-EN3, SI-EN3D
	MECHATROLINK-II	SI-T3
	Modbus/TCP (Single-Port, Dual Port)	SI-EM3, SI-EM3D
	POWERLINK	SI-EL3
	PROFIBUS-DP	SI-P3
	PROFINET	SI-EP3

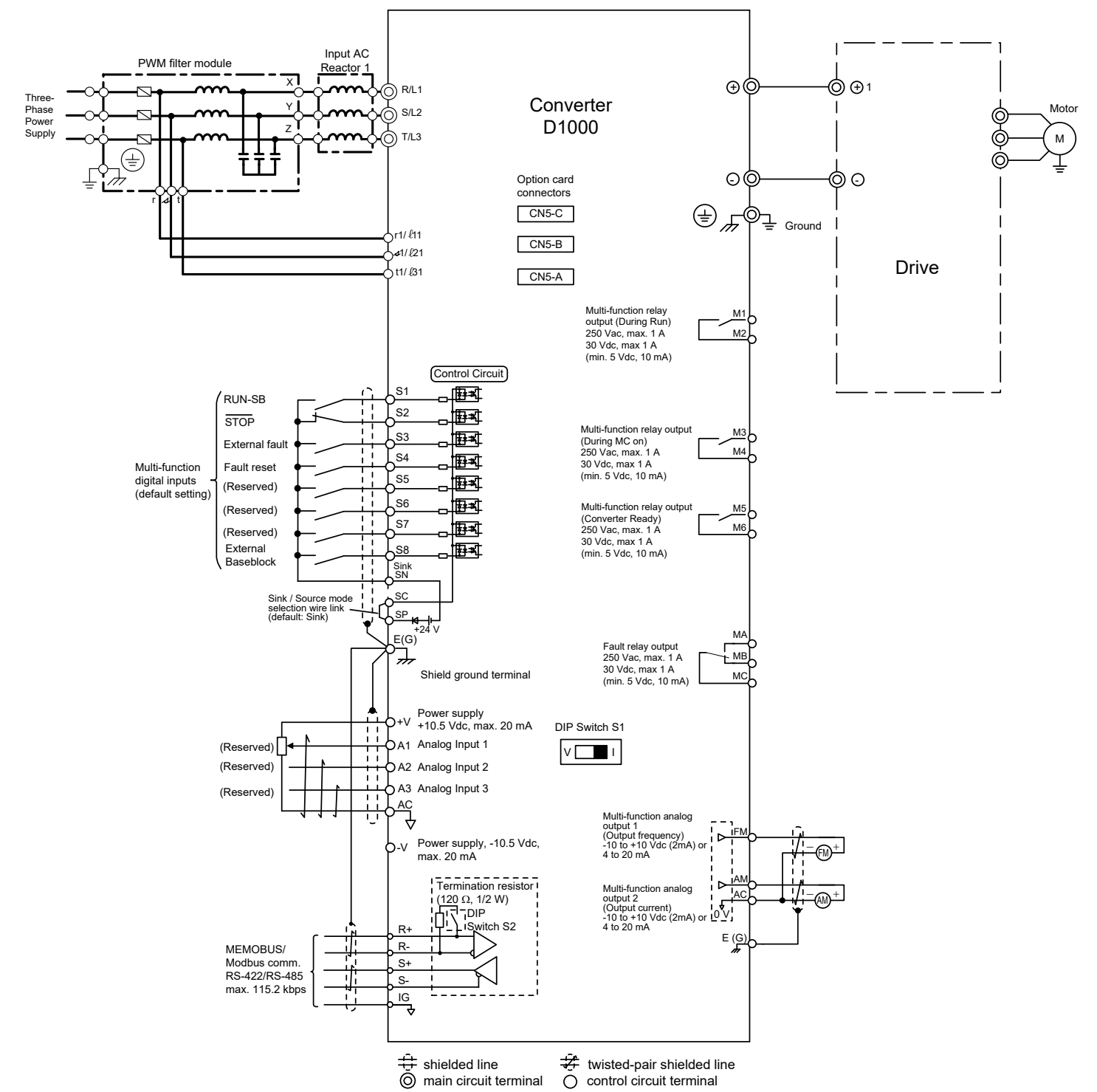

# Dimensions

## 200 V Models from 5 HP to 150 HP

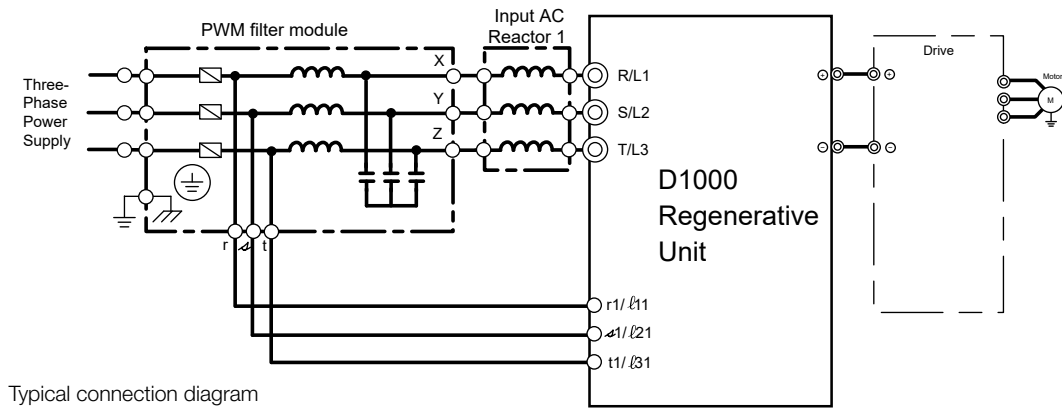

Typical connection diagram

## 400 V Models from 5 HP to 200 HP

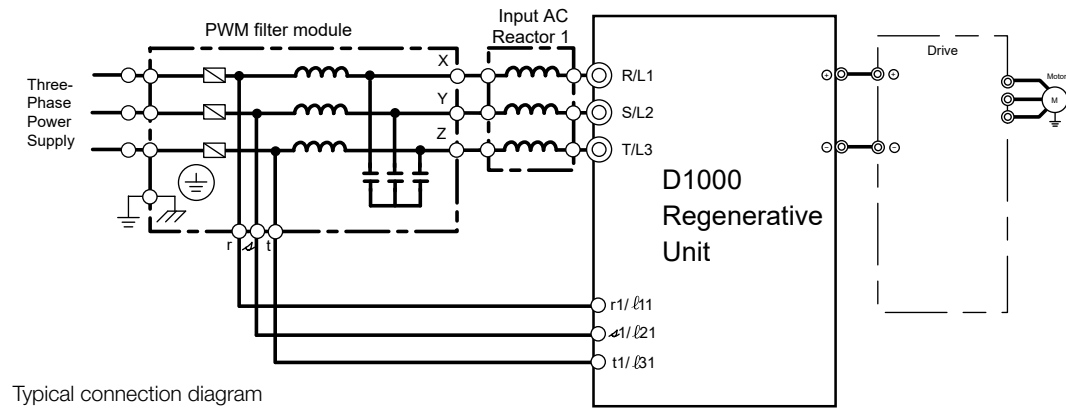

Typical connection diagram

## D1000 Regenerative Converter Unit 200 V

D1000 System Kit No.	Component Name	Component Model Number	Dimensions (in)			Weight (lb)
			W	H	D	
D1000-240-5HP	D1000	CIMR-DU2A0005BAA	11.81	7.09	7.36	11
	Input AC Reactor 1	URX000451	5.24	6.30	6.77	18
	PWM Filter Module	UFI000349	6.93	8.23	11.22	14
D1000-240-10HP	D1000	CIMR-DU2A0010BAA	11.81	7.09	7.36	11
	Input AC Reactor 1	URX000452	6.81	8.07	7.05	31
	PWM Filter Module	UFI000350	7.24	8.23	11.61	20
D1000-240-20HP	D1000	CIMR-DU2A0020BAA	14.37	8.66	7.76	18
	Input AC Reactor 1	URX000453	9.88	10.47	9.37	62
	PWM Filter Module	UFI000351	10.43	9.13	11.85	31
D1000-240-30HP	D1000	CIMR-DU2A0030AAA	17.72	10.83	10.16	46
	Input AC Reactor 1	URX000454	11.42	10.47	10.24	84
	PWM Filter Module	UFI000352	11.06	10.24	12.01	35
D1000-240-50HP	D1000	CIMR-DU2A0050AAA	21.65	12.80	11.14	71
	Input AC Reactor 1	URX000455	13.15	12.99	10.55	143
	PWM Filter Module	UFI000353	13.70	11.42	13.98	60
D1000-240-75HP	D1000	CIMR-DU2A0065AAA	27.76	17.72	12.99	126
	Input AC Reactor 1	URX000456	13.50	12.60	12.05	174
	PWM Filter Module	UFI000354	13.78	11.42	13.86	84
D1000-240-100HP	D1000	CIMR-DU2A0090AAA	27.76	17.72	12.99	134
	Input AC Reactor 1	URX000457	15.04	14.96	12.60	225
	PWM Filter Module	UFI000355	15.24	11.42	13.86	95
D1000-240-150HP	D1000	CIMR-DU2A0130AAA	31.50	19.69	13.78	187
	Input AC Reactor 1	URX000458	17.17	17.52	15.20	362
	PWM Filter Module	UFI000356	19.69	13.78	11.02	137

Note: Dimensions and weights are approximates.

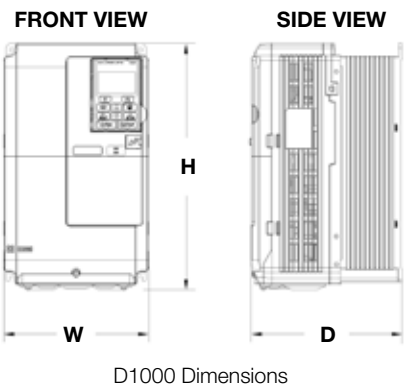

D1000 Dimensions

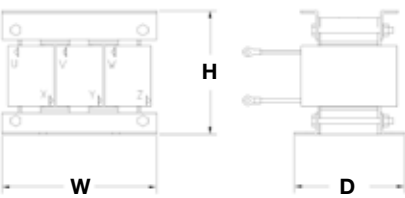

AC Reactor Dimensions

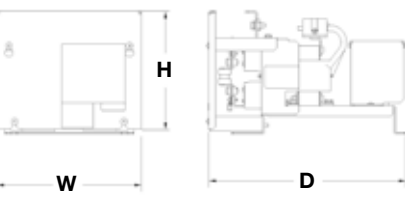

PWM Filter Dimensions

## D1000 Regenerative Converter Unit 400 V

D1000 System Kit No.	Component Name	Component Model Number	Dimensions (in)			Weight (lb)
			W	H	D	
D1000-480-5HP	D1000	CIMR-DU4A0005BAA	11.81	7.09	7.36	11
	Input AC Reactor 1	URX000459	5.24	6.30	6.38	16
	PWM Filter Module	UFI000357	6.93	8.23	11.22	15
D1000-480-10HP	D1000	CIMR-DU4A0010BAA	11.81	7.09	7.36	11
	Input AC Reactor 1	URX000460	6.81	8.11	6.54	29
	PWM Filter Module	UFI000358	7.01	8.23	11.61	20
D1000-480-20HP	D1000	CIMR-DU4A0020BAA	14.37	8.66	7.76	18
	Input AC Reactor 1	URX000461	8.35	9.45	8.27	57
	PWM Filter Module	UFI000359	10.43	9.13	11.85	33
D1000-480-30HP	D1000	CIMR-DU4A0030AAA	17.72	10.83	10.16	46
	Input AC Reactor 1	URX000462	11.42	10.43	9.57	75
	PWM Filter Module	UFI000360	11.54	10.24	12.01	37
D1000-480-40HP	D1000	CIMR-DU4A0040AAA	17.72	10.83	10.16	46
	Input AC Reactor 1	URX000463	11.22	10.55	10.71	97
	PWM Filter Module	UFI000361	11.54	10.24	12.01	42
D1000-480-60HP	D1000	CIMR-DU4A0060AAA	21.65	12.80	11.14	75
	Input AC Reactor 1	URX000464	13.03	12.99	10.75	123
	PWM Filter Module	UFI000362	13.70	11.42	13.98	60
D1000-480-100HP	D1000	CIMR-DU4A0100AAA	21.65	12.80	11.14	79
	Input AC Reactor 1	URX000465	14.41	12.60	12.17	192
	PWM Filter Module	UFI000363	15.16	11.42	13.98	86
D1000-480-150HP	D1000	CIMR-DU4A0130AAA	31.50	19.69	13.78	187
	Input AC Reactor 1	URX000466	15.04	15.16	12.99	269
	PWM Filter Module	UFI000364	19.69	13.78	14.96	141
D1000-480-200HP	D1000	CIMR-DU4A0185AAA	31.50	19.69	13.78	187
	Input AC Reactor 1	URX000467	16.69	17.72	13.19	331
	PWM Filter Module	UFI000365	19.69	13.78	14.96	161

Note: Dimensions and weights are approximates.

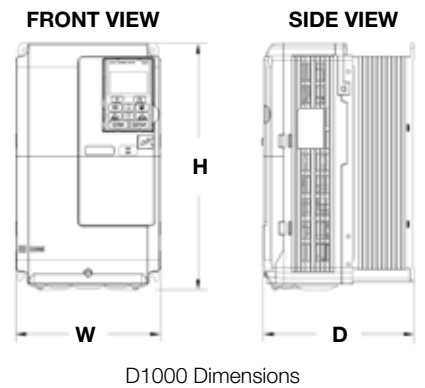

D1000 Dimensions

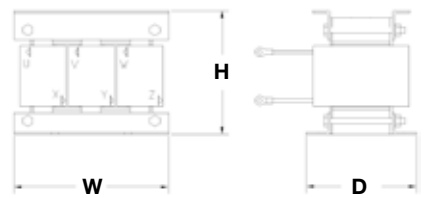

AC Reactor Dimensions

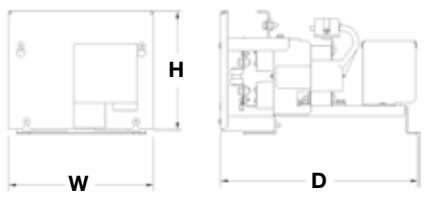

PWM Filter Dimensions

# Dimensions

## 400 V Models from 300 HP to 400 HP

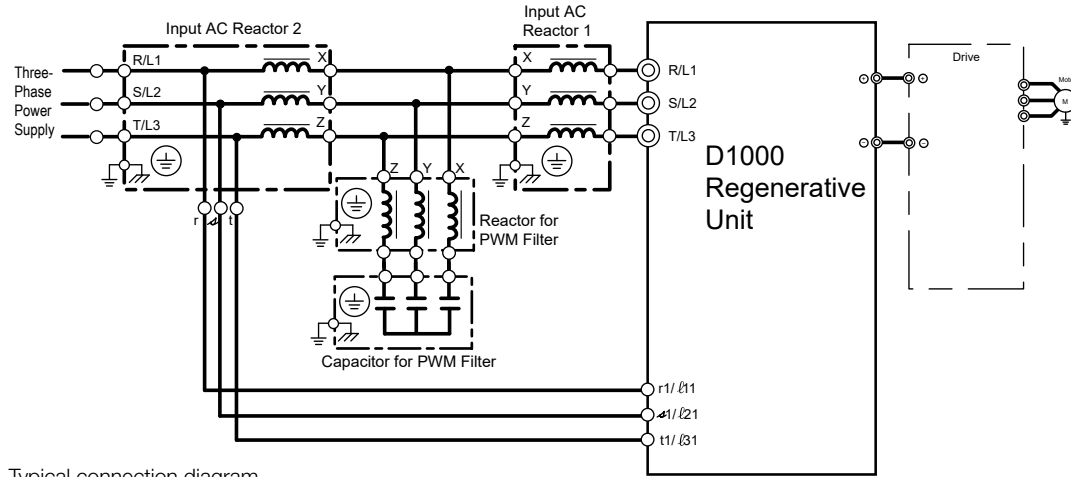

Typical connection diagram

## 400 V 750 HP Model

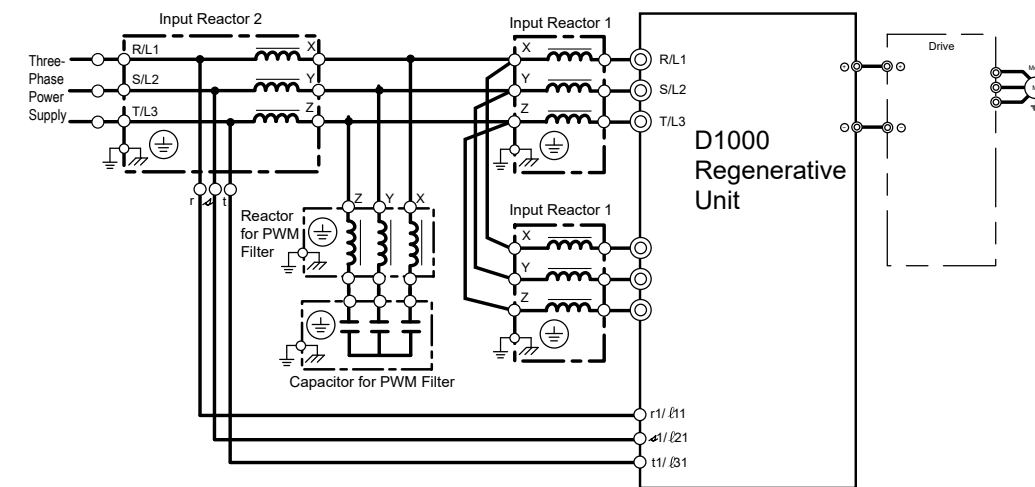

Typical connection diagram

## D1000 Regenerative Converter Unit 400 V

D1000 System Kit No.	Component Name	Component Model Number	Dimensions (in)			Weight (lb)
			W	H	D	
D1000-480-300HP	D1000	CIMR-DU4A0270AAA	44.88	26.38	14.57	403
	Input AC Reactor 1	URX000468	18.98	20.08	16.14	489
	Input AC Reactors 2	URX000471	12.83	12.99	12.80	132
	Reactor for PWM Filter	URX000474	5.31	6.30	5.79	14
	Capacitor for PWM Filter	UCA000062	19.76	17.24	5.04	60
D1000-480-400HP	D1000	CIMR-DU4A0370AAA	44.88	26.38	14.57	428
	Input AC Reactor 1	URX000469	21.61	22.05	17.13	646
	Input AC Reactors 2	URX000472	15.04	15.16	13.78	225
	Reactor for PWM Filter	URX000475	5.91	7.09	6.10	17
	Capacitor for PWM Filter	UCA000063	23.70	17.24	5.04	73

Note: Dimensions and weights are approximates.

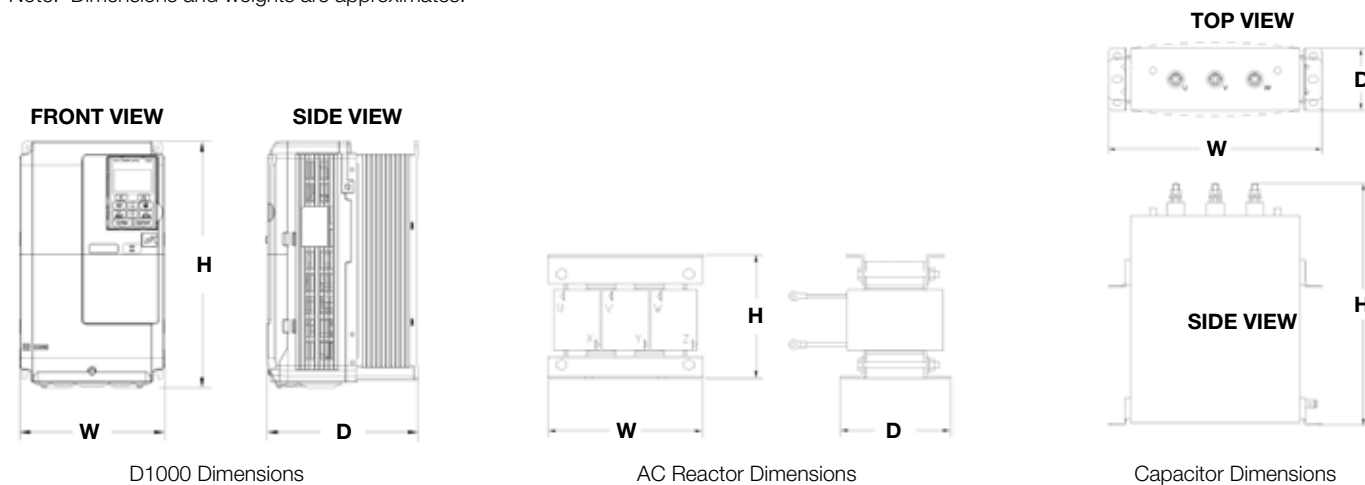

D1000 Dimensions

AC Reactor Dimensions

Capacitor Dimensions

## D1000 Regenerative Converter Unit 400 V

D1000 System Kit No.	Component Name	Component Model Number	Dimensions (in)			Weight (lb)
			W	H	D	
D1000-480-750HP	D1000	CIMR-DU4A0630AAA	54.33	49.21	14.57	911
	Input AC Reactor 1 (Qty 2)	URX000469	21.61	22.05	17.13	646
	Input AC Reactors 2	URX000473	21.46	17.80	5.12	379
	Reactor for PWM Filter	URX000476	7.48	8.27	6.73	26
	Capacitor for PWM Filter	UCA000064	22.91	27.36	5.04	121

Note: Dimensions and weights are approximates.

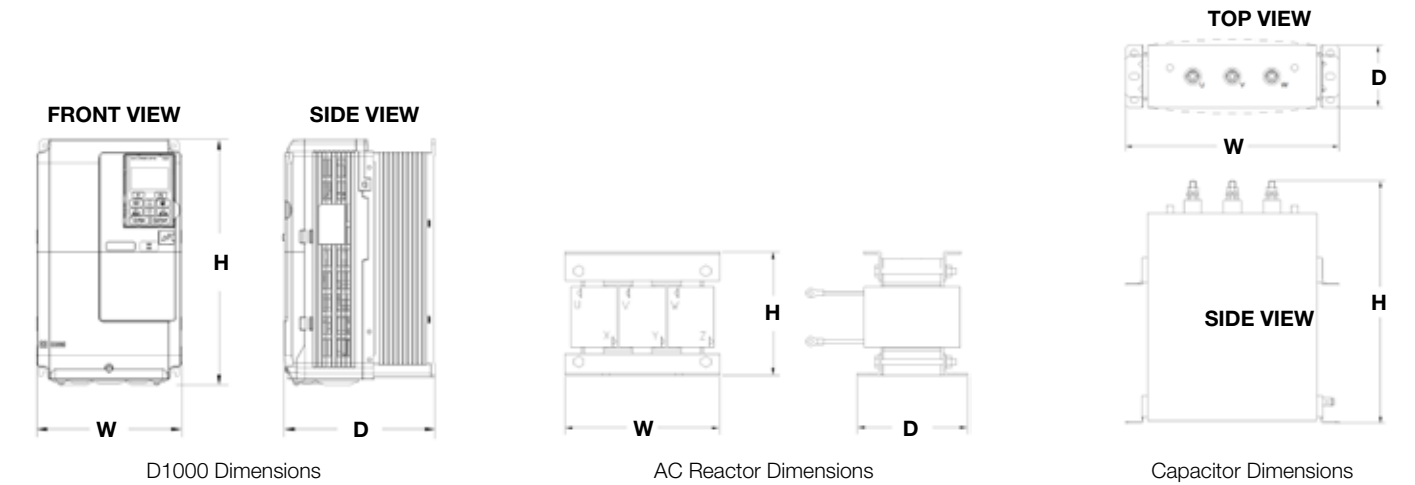

D1000 Dimensions

AC Reactor Dimensions

Capacitor Dimensions





Yaskawa is the leading global manufacturer of low and medium voltage variable frequency drives, servo systems, machine controllers and industrial robots. Our standard products, as well as tailor-made solutions, are well known and have a high reputation for outstanding quality and reliability.