



- MSIP es una máquina síncrona de imanes permanentes, con encoder, muy compacta y robusta.
- Tiene una fácil instalación y mantenimiento nulo, bajo consumo y gran precisión.
- Necesita poco espacio.

- *MSIP is a permanent magnet synchronous machine, with encoder, compact and strong.*
- *Easy to install and maintenance free, low consumption and high precision.*
- *Needs small space.*

## ventajas de la máquina síncrona

- Mayor eficiencia
- Mayor confortabilidad (silenciosa y sin vibraciones)
- Mayor fiabilidad
- Menor peso y tamaño

- Ahorro de mantenimiento
- Ahorro del reductor
- Ahorro de energía (hasta 50%)

## advantages of the synchronous machine

- *Higher efficiency*
- *Higher confortability (No noise, no vibrations)*
- *Higher reliability*
- *Lower weight and volume*

- *Maintenance saving*
- *Gear-box saving*
- *Energy savings (Up to 50%)*

TIPO	L	Polea /Tr. Sheave Ø320: Dp=Ø324			Polea /Tr. Sheave Ø400: Dp=Ø404			FANS
		A	B	C	A	B	C	
SILA -225.28-20	251.5	177	177	663.5	244	177	2	
SILA -225.44-20	331.5			672.5				
SILA -225.52-20	371.5			743.5				
SILA -225.60-20	411.5			752.5				
SILA -225.64-20	431.5			792.5				
SILA -225.28-20	251.5	184	184	670.5	184	184	4	
SILA -225.44-20	331.5			679.5				
SILA -225.52-20	371.5			783.5				
SILA -225.60-20	411.5			823.5				
SILA -225.64-20	431.5			832.5				
SILA -225.72-20	471.5			830.5				
				859.5				
				890.5				

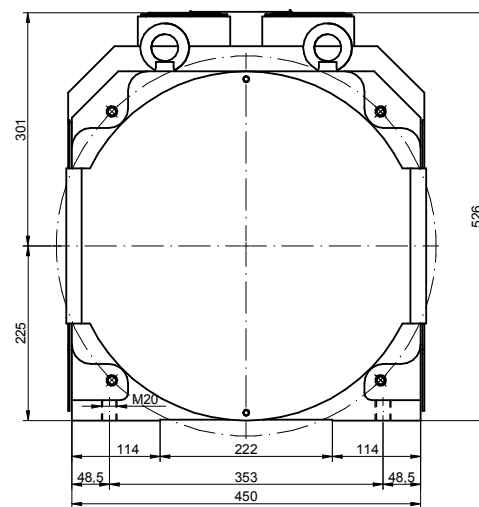
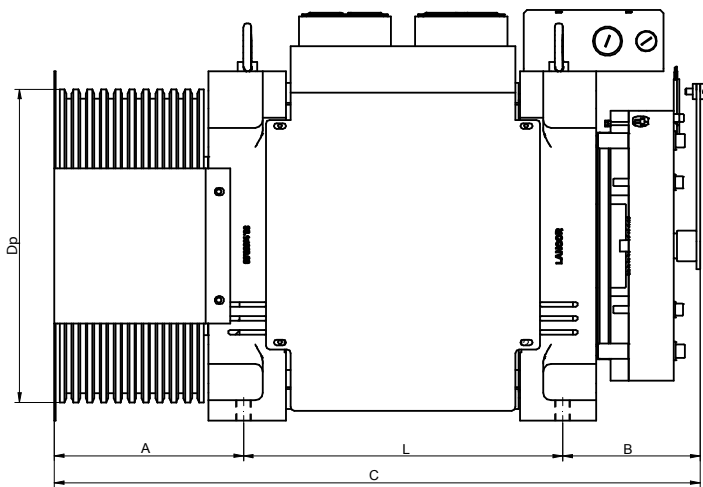

comparativa / comparative

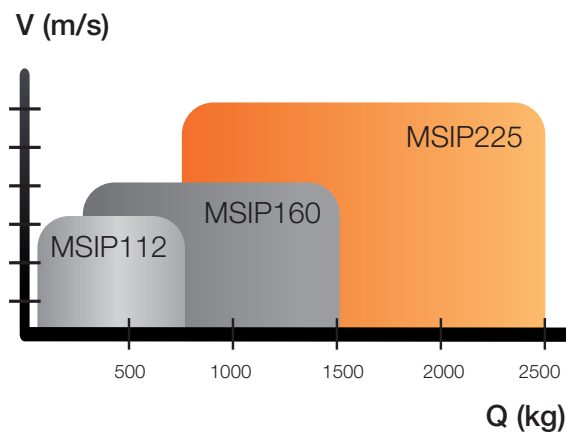

Carga Estática / Static load	10.000 Kg
Rango velocidades / Speed	1-3 m/s
Protección / Protection	IP21

Cálculos basados en un rendimiento del hueco de 0,7  
Calculations based on a shaft efficiency of 0,7

Los frenos utilizados están certificados por la TÜV de acuerdo con la Norma EN81-1+A3  
The brakes used are TÜV certificated based on the EN81-1+A3 standards

SUSP. / ROPING	POSICION / ITEM	TIPO / TYPE	RATED LOAD Q (Kg.)	POLEA Ø TR. SHEAVE	Nº CANALES / GROOVES	Ø CABLES / ROPES Ø	KW	PAR / TORQUE (Nm)	RPM	HZ
Standard	1:1	10 MSIP225.28-20	630	320	10	8	4,4	710	60	10
		11 MSIP225.44-20	800				5,6	900		
		12 MSIP225.52-20	1000				7	1130		
		13 MSIP225.60-20	1250				9	1410		
		14 MSIP225.52-20	800				5,6	1120		
	15 MSIP225.60-20	1000	7	1390						
	2:1	16 MSIP225.44-20	1250	320	10	8	8,8	700	120	20
		17 MSIP225.44-20	1600				11,2	900		
		18 MSIP225.52-20	2000				14	1120		
		19 MSIP225.64-20	2500				17,5	1400		
20 MSIP225.52-20		1600	11,2				1120			
21 MSIP225.64-20		2000	14				1400			
Pro	1:1	10 MSIP225.44-20	630	320	10	8	6,2	710	95,4	16
		11 MSIP225.44-20	800				9	900		
		12 MSIP225.60-20	1000				11,3	1120		
		13 MSIP225.72-20	1250				14,1	1400		
		14 MSIP225.60-20	800				9	1120		
	15 MSIP225.68-20	1000	11,3	1410						
	2:1	16 MSIP225.44-20	1250	320	10	8	14	700	191	32
		17 MSIP225.52-20	1600				18	900		
		18 MSIP225.60-20	2000				22,4	1120		
		19 MSIP225.72-20	2500				28	1400		
20 MSIP225.60-20		1600	17,9				1120			
21 MSIP225.72-20		2000	22,4				1400			
High Rise	1:1	10 MSIP225.44-20	630	320	10	8	11	710	150	25
		11 MSIP225.52-20	800				14	900		
		12 MSIP225.64-20	1000				17,5	1120		
	2:1	13 MSIP225.64-20	800	320	10	8	14	1120	299	50
		14 MSIP225.52-20	1250				22	700		
		15 MSIP225.60-20	1600				28,5	900		
		16 MSIP225.72-20	2000				35	1120		
		17 MSIP225.60-20	1250				22	880		
18 MSIP225.72-20	1600	28	1120							

<b>Standard</b>	Recorrido máximo 30m (1m/s, 40%ED, 180ch, 150% sobrecarga)	Travel height max 30m (1m/s, 40%ED, 180ch, 150% overload)
<b>Pro</b>	Recorrido máximo 75m (1,6m/s, 50% ED, 240ch, 150% sobrecarga)	Travel height max 75m (1,6m/s, 50%ED, 240ch, 150% overload)
<b>High Rise</b>	Recorrido máximo 130m (2,5m/s, 50% ED, 240ch, 180% sobrecarga)	Travel height max 130m (2,5m/s, 50% ED, 240ch, 180% overload)

Otras configuraciones disponibles bajo solicitud / Other configurations available upon request